

SLIGHTLY FREQUENCY-SHIFTED REFERENCE ULTRA-WIDEBAND (UWB) RADIO: TR-UWB WITHOUT THE DELAY ELEMENT

Dennis L. Goeckel and Qu Zhang
Department of Electrical and Computer Engineering
University of Massachusetts at Amherst
Amherst, Massachusetts 01003-9292
Email: {goeckel,quzhang}@ecs.umass.edu

ABSTRACT

Recently, there has been significant interest in ultra-wideband (UWB) radio techniques. A promising UWB technique being widely considered for low data rate applications, such as those often encountered in sensor networks, is the transmitted reference (TR) UWB scheme. However, the standard TR-UWB scheme, while often motivated by the simplicity of its receiver, is still dogged by implementation concerns. In particular, the receiver requires an extremely wideband delay element, which is difficult to incorporate into low-power integrated systems. In this paper, a transmitted-reference scheme is proposed in which the separation between the data and reference signals, rather than being a time delay, is a slow rotation over the symbol interval. This provides a (slightly) frequency-shifted reference that, while orthogonal to the data-bearing pulse, still goes through a nearly equal channel. A detailed analysis of the proposed scheme is provided, and numerical results demonstrate that the proposed system not only achieves the primary goal of providing a much simpler receiver architecture, but also that it outperforms the standard TR-UWB system.

I. INTRODUCTION

Ultra-wideband (UWB) communication systems have emerged as a potential alternative to conventional communication systems for short-range, low-power wireless applications. From a regulatory standpoint, the extremely low power density of UWB communications has motivated the federal communications commission (FCC) of the United States to allow UWB systems to operate in bands already allocated to other radios, thus helping to solve the frequency allocation problem that often inhibits high data rate wireless communication systems. From a technical standpoint, the extremely wide bandwidth offers a number of *potential* advantages for wireless

This paper is based in part upon work supported by the Army Research Office under Contract DAAD10-01-1-0477 and employed equipment obtained under National Science Foundation Grant EIA-0080119.

transmission versus narrowband alternatives, including the ability to carry very high data rates, an extremely large amount of frequency diversity to combat multipath fading, and significant mitigation of both multi-user and non-system interference.

However, the large bandwidth of UWB systems can also make receiver design very difficult in traditional UWB systems that employ either antipodal or pulse-position modulation with extremely short pulses [1]. For simple low-power UWB receivers, digitization of the entire signaling bandwidth is far from being realizable in analog-to-digital (A/D) conversion technology. Hence, many UWB receivers that are largely digital have some number of analog correlators to collect signal energy in a front-end rake receiver type architecture [2]. Unfortunately, due to the many resolvable paths in the standard fading environment, efficient energy collection in such an architecture can be costly, and, even if allowable from a circuit complexity standpoint, can present problems in terms of channel estimation [3]. These implementation problems have been a large motivation for the industry shift away from traditional impulsive UWB or direct-sequence UWB to the multiband UWB approach for short-range high data rate applications.

One method of addressing the receiver complexity problems in the impulse-based UWB system, particularly in low data rate systems, is through the use of the transmitted reference (TR) UWB system [4]. In the TR-UWB system, each frame consists of two pulses. The first is a “reference pulse”, which is constant across frames. The second, which follows at some known delay D , is a “data pulse” whose polarity indicates the data bit. In low data rate systems, these two pulses are then repeated over many frames to allow energy aggregation at the receiver. In the standard receiver configuration, which is shown in Figure 1, the received signal is correlated against a delayed version of itself to produce the decision variable. This simple TR-UWB architecture has a number of attractive properties, such as multipath energy gathering, simple timing acquisition, and that the channel need only be constant over the frame time. In exchange for

the ostensibly simple receiver, TR-UWB systems are generally viewed as inferior to standard UWB systems in error performance due to the “noise cross noise” terms arising in the receiver of Figure 1. However, some recent work has suggested that standard UWB systems (e.g. antipodal systems) incur a similar performance loss as that observed in the TR-UWB system when errors in the channel estimates required to determine the combining coefficients for the rake receiver are considered [5].

However, despite the simplicity at first glance of the TR-UWB receiver in Figure 1, implementation can be daunting. In particular, the delay element, which must handle a wideband analog signal, is difficult to build in the low-power integrated fashion desirable for the TR-UWB receiver. Furthermore, many of the improved versions of the TR-UWB system proffered in the literature further exacerbate this problem by needing to extend this delay [6], [7], [8].

In this paper, the main motivation is to prescribe an effective TR-UWB system that avoids the delay element required in the standard TR-UWB receiver. Because the implementation of a frequency translation of a wideband signal is much simpler than the delay of the same signal, the technique considered here is to employ a very carefully selected frequency-translated reference; in other words, the reference is translated in frequency (rather than time) to be orthogonal to the data-bearing signal. The work of [9] put forward a frequency-translated reference as an example of a non-standard TR-UWB system covered by their generalized framework for TR-UWB. However, that example immediately illustrates the main perils of this avenue of approach. Since the data pulse must go through approximately the same channel as the reference pulse, frequency orthogonality obtained by simply shifting the data pulse is ineffective, because the frequency separation between the pulses exceeds the coherence frequency of any reasonable fading channel. This is addressed in [9] by restricting the reference pulse shape to be one whose frequency response consists of the union of a large number of disjoint regions, with gaps in between these disjoint regions for the data signal’s frequency response. The construction of such a pulse is complicated. Hence, we seek a solution that does not require modification of the basic UWB pulse shape.

For a system employing any arbitrary UWB pulse shape, our goal will be achieved if a small frequency shift can be prescribed that makes the data signal orthogonal to the reference signal. The key observation that leads to the solution proffered here is to recognize that this orthogonality of the reference and data signals does not have to be enforced over each frame period but rather

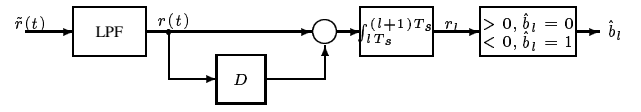

Fig. 1. (U) Receiver for a standard TR-UWB communication system, where $\tilde{r}(t)$ is the received signal, and $r(t)$ is a lowpass-filtered version of such. The signal is multiplied by a delayed version of itself and the result integrated over the symbol period T_s , which can consist of many frames, each of duration T_f , in low data rate UWB systems. A threshold decision is made on r_l to decode the data bit for the current symbol.

over a symbol period. Hence, a frequency offset between the reference impulse train and data impulse train is prescribed that is only the inverse of the symbol period. For low data rate applications, this frequency shift is well below the frequency coherence of the channel, and, hence, as desired, the reference serves as a suitable (albeit not perfect, because it is not only noisy but slightly shifted in frequency) reference for the data-bearing signal.

In this paper, this slightly frequency-shifted reference UWB system is introduced and characterized. After prescribing the transmitted signal per the guidelines above, an analogous receiver to that in Figure 1 is put forward for the proposed system. The resulting system is carefully characterized analytically. Numerical results are presented to compare the performance of the proposed system to standard TR-UWB.

The contributions of this paper are potentially significant to the implementation of low data rate UWB systems, which include: (1) the recognition that a properly frequency-shifted reference can remove the requirement for a delay element at the receiver in TR-UWB systems, (2) the prescription of a scheme that provides such a reference for low data rate applications, and (3) the performance characterization of the proposed scheme.

II. THE PROPOSED SCHEME

Throughout this paper, a baseband UWB system will be assumed. Since low data rate applications are targeted, a symbol interval $T_s = N_f T_f$ consists of $N_f \gg 1$ frames, each of duration T_f and carrying one data pulse of the UWB transmission. In the standard TR-UWB system [4], as described in Section I, the transmitted signal over the k^{th} frame for transmission of the l^{th} symbol is given by:

$$\sqrt{\frac{E_s}{2}} p(t - lT_s - kT_f) + (-1)^{b_l} \sqrt{\frac{E_s}{2}} p(t - lT_s - kT_f - D)$$

where E_s is the transmitted energy per symbol period, $b_l \in \{0, 1\}$ is the information bit to be transmitted during the l^{th} symbol period, and $p(\cdot)$ is a normalized UWB pulse shape with energy $\frac{1}{N_f}$, approximate bandwidth W , and approximate support on $[0, T_p]$ with $T_p \ll T_f$. Hence, the standard TR-UWB signal over the l^{th} symbol interval can be written as:

$$x(t) = \sum_{k=0}^{N_f-1} \left(\sqrt{\frac{E_s}{2}} p(t - lT_s - kT_f) + (-1)^{b_l} \sqrt{\frac{E_s}{2}} p(t - lT_s - kT_f - D) \right)$$

Per Section I, this system's standard receiver for recovery of bit b_l , as shown in Figure 1, requires the ability to delay the wideband received signal by D , which can be difficult in low-power integrated receivers.

Hence, a method is sought to obtain an orthogonal reference that can be more easily recovered by the receiver. Per Section I, frequency translation of wideband signals can be readily accomplished with a mixer. The simplest method for achieving such is to simply separate the data and reference pulses by a frequency separation $f_h > W$, thus ensuring orthogonality since the frequency bands of the data-bearing and reference signals do not overlap. Since the data-bearing and reference signals must share an identical channel, this reference is only effective when f_h is less than the channel coherence frequency $(\Delta f)_c$. Since W is on the order of GHz in impulsive UWB systems, the application space of such an approach is quite limited, but we observe that, if it could be made applicable, it would yield our desired receiver simplification.

Here, the fact that the targeted application is low data rate systems, where one symbol interval consists of many frames, is exploited. In particular, the frequency shift of the data pulse relative to the reference pulse need not be accomplished over a frame but rather a symbol interval, which, in contrast to [9], allows *significant* overlap of the frequency bands which the data-bearing and reference signal occupy. To develop this frequency-shifted reference UWB (FSR-UWB) approach, define a basic template signal $u(t)$, which consists of N_f unmodulated UWB pulses with a "standard" UWB pulse shape $p(\cdot)$, as:

$$u(t) = \sum_{k=0}^{N_f-1} p(t - kT_f) \quad (1)$$

We note, in passing, that the regular structure of the pulses in $u(t)$ is not necessary for this approach to work (i.e. the pulses can easily be dithered if desired). The

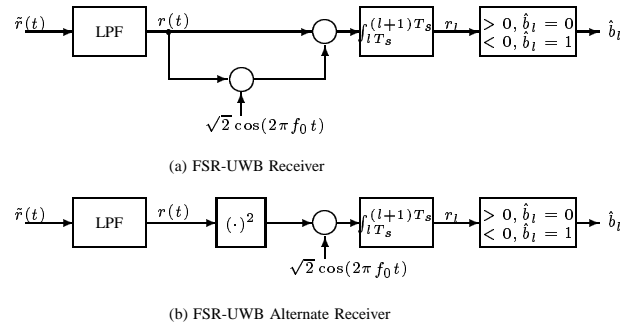

Fig. 2. (U) Receiver for the proposed FSR-UWB system. Note that the delay element in Figure 1 has been replaced by a mixer in (a). Since multiplication is commutative, the receiver in (a) can be drawn in the more convenient form given in (b).

reference pulse is set to be a scaled version of $u(t)$, and the data pulse is set as a frequency shifted version of this signal that is orthogonal to it *over the symbol interval*. Thus, defining $f_0 = \frac{1}{T_s}$ as the frequency shift of the data pulse relative to the reference, the transmitted signal over interval $[lT_s, (l+1)T_s]$ is given by:

$$\begin{aligned} x(t) &= \left(\sqrt{E_p} + \sqrt{2E_d}(-1)^{b_l} \cos(2\pi f_0 t) \right) u(t - lT_s) \\ &\approx \sum_{k=0}^{N_f-1} \left(\sqrt{E_p} + \sqrt{2E_d}(-1)^{b_l} \cos(2\pi f_0 kT_f) \right) p(t - lT_s - kT_f) \end{aligned} \quad (2)$$

where E_p and E_d are the energy per symbol invested in the reference signal and the data-bearing signal, respectively, and (2) is obtained by noting that the support of $p(\cdot)$ is very small relative to the inverse of the bandwidth of $\cos(2\pi f_0 t)$. As desired, the frequency separation of the reference signal and data signal is only $\frac{1}{T_s}$, which for low data rate applications (say, less than 100 kbits/s) and most fading environments is well below the coherence frequency of the channel. Furthermore, (2) indicates that this whole scheme can be viewed simply as a special form of spreading on the UWB impulse train that allows for simple recovery at the receiver.

The receiver for the proposed system is shown in Figure 2. Figure 2(a) shows the natural conversion of the receiver of Figure 1, but, recognizing that multiplication is commutative results in the receiver in Figure 2(b). The latter is useful not only for analysis, but also for interpretation and relation of the scheme to other potential schemes, such as on-off keying with energy detection. To understand the motivation for this receiver (besides the obvious conversion from Figure 1), let $r(t) = x(t)$ (i.e. ignore the noise for now) and, without loss of generality,

consider the receiver output for the first bit (b_0):

$$\begin{aligned}
r_0 &= \int_0^{T_s} x^2(t) \sqrt{2} \cos(2\pi f_0 t) dt \\
&= \sqrt{2} E_p \int_0^{T_s} u^2(t) \cos(2\pi f_0 t) dt \\
&\quad + 4\sqrt{E_p E_d} (-1)^{b_0} \int_0^{T_s} u^2(t) \cos^2(2\pi f_0 t) dt \\
&\quad + 2\sqrt{2} E_d \int_0^{T_s} u^2(t) \cos^3(2\pi f_0 t) dt \quad (3)
\end{aligned}$$

Throughout this paper, there will be many integrals of the form:

$$\int_0^{T_s} u^2(t) g(t) dt$$

where $g(t)$ is a narrowband signal, and $u(t)$, as defined above, is a sequence of N_f short pulses equally spaced over T_s . These types of integrals can be simplified through the following argument:

$$\begin{aligned}
\int_0^{T_s} u^2(t) g(t) dt &= \int_0^{T_s} \left(\sum_{k=0}^{N_f-1} p(t - kT_f) \right)^2 g(t) dt \\
&= \sum_{k=0}^{N_f-1} \int_0^{T_s} p^2(t - kT_f) g(t) dt \\
&\approx \sum_{k=0}^{N_f-1} \int_0^{T_s} p^2(t - kT_f) g(kT_f) dt \\
&= \frac{1}{N_f} \sum_{k=0}^{N_f-1} g(kT_f) \\
&\approx \int_0^{T_s} g(t) dt
\end{aligned}$$

where the second line is due to the orthogonality of pulses from different frames, the approximation in the third line arises because the narrowband signal $g(\cdot)$ can be approximated as constant over the small interval T_p , and the approximation in the last line comes from the observation that $N_f \gg 1$ for the applications of interest and the definition of the Riemann integral. Using basic trigonometric identities and this simplification in (3) yields:

$$r_0 = 2\sqrt{E_p E_d} (-1)^{b_0}$$

The partitioning of the symbol energy E_s between E_p and E_d should be done to optimize the output signal-to-noise ratio (SNR). However, as will be demonstrated later, the “noise cross noise” terms will dominate receiver performance at the error rates of interest, and thus a partitioning to maximize the noiseless r_0 is sufficient and

will greatly simplify notation. Clearly, this maximization is completed by setting $E_p = E_d = \frac{E_s}{2}$, which yields:

$$r_0 = (-1)^{b_0} E_s$$

III. PERFORMANCE ANALYSIS

In this section, the performance of the proposed scheme on additive white Gaussian noise (AWGN) and multipath fading channels is considered, and the results are compared to that of the standard transmitted-reference scheme.

A. ADDITIVE WHITE GAUSSIAN NOISE

The received signal is given by

$$\tilde{r}(t) = x(t) + \tilde{n}(t)$$

where $\tilde{n}(t)$ is a zero-mean Gaussian random process with (two-sided) power spectral density $S_{\tilde{n}}(f) = \frac{N_0}{2}$. Assuming that the lowpass filter at the front end of the receiver passes the transmitted signal without distortion, the signal at its output is given by:

$$r(t) = x(t) + n(t)$$

where $n(t)$ is a zero-mean Gaussian random process with power spectral density $S_n(f) = |H(f)|^2 \frac{N_0}{2}$, where $H(f)$ is the frequency response of the front-end filter.

Without loss of generality, consider again reception of the signal corresponding to the first bit b_0 . The integrator output r_0 can be expressed as:

$$\begin{aligned}
r_0 &= (-1)^{b_0} E_s + 2\sqrt{2} \int_0^{T_s} x(t) n(t) \cos(2\pi f_0 t) dt \\
&\quad + \sqrt{2} \int_0^{T_s} n^2(t) \cos(2\pi f_0 t) dt \quad (4)
\end{aligned}$$

where the first term has been evaluated using the (noiseless) analysis of Section II. The latter two terms, which will be denoted the “noise terms”, will be grouped into a single random variable n_0 . Following the argument for the standard TR-UWB system [4], it is straightforward to establish that n_0 is approximately Gaussian. Hence, only its mean and variance need to be calculated to complete the performance characterization.

It is straightforward (but tedious) to show that n_0 is zero-mean with variance [10]:

$$E[n_0^2] = \frac{5}{2} E_s N_0 + T_s N_0^2 W \quad (5)$$

The bit error probability of the proposed system on AWGN channels then follows easily as:

$$P_{FSR-UWB,AWGN} = Q \left(\frac{E_s}{\sqrt{\frac{5}{2} E_s N_0 + T_s N_0^2 W}} \right) \quad (6)$$

From [10], the bit error probability of standard TR-UWB on an AWGN channel is derived as:

$$P_{TR-UWB,AWGN} = Q\left(\frac{E_s}{\sqrt{4E_s N_0 + 2T_s N_0^2 W}}\right) \quad (7)$$

Note the difference in the two formulas. In particular, at low-to-moderate SNRs where the “noise cross noise” term dominates, the proposed system will demonstrate a 1.5 dB gain over the standard TR-UWB system. At high SNRs, where the “signal cross noise” term dominates, the proposed system will demonstrate a 2 dB gain over the standard TR-UWB system.

B. MULTIPATH FADING

In standard TR-UWB systems with no interframe and interpulse interference, the probability of error conditioned on the multipath fading channel is the same as in AWGN except with a modified pulse shape. However, this is not true for the proposed system, since there is a loss incurred due to the reference pulse traveling through a slightly different (although greatly overlapping) frequency band than the data pulse. In this section, the effects of such are studied.

For the multipath fading channel, the received signal is denoted by:

$$\tilde{r}(t) = h(t) * x(t) + \tilde{n}(t)$$

where $h(t)$ is the channel impulse response. Here, a discrete path model is assumed for the channel; hence, $h(t)$ can be written as:

$$h(t) = \sum_{l=0}^{L-1} h_l \delta(t - \tau_l) \quad (8)$$

where L is the number of paths, h_l is the amplitude of the l^{th} path, $\delta(\cdot)$ is the Dirac delta function, and τ_l is the delay of the l^{th} path.

The noise analysis of the previous section still holds with the modified pulse shape $h(t) * p(t)$. However, the desired signal component changes as follows:

$$\begin{aligned} r_0 &= \int_0^{T_s} \left(\sum_{l=0}^{L-1} h_l x(t - \tau_l) \right)^2 \sqrt{2} \cos(2\pi f_0 t) dt \\ &\simeq (-1)^{b_0} E_s \sum_{l=0}^{L-1} \sum_{m=0}^{L-1} h_l h_m \rho(|\tau_m - \tau_l|) \cdot \\ &\quad \left(\frac{1}{2} \cos(2\pi f_0 \tau_l) + \frac{1}{2} \cos(2\pi f_0 \tau_m) \right) \end{aligned}$$

where $\rho(|\tau_m - \tau_l|)$ denotes the correlation of $p(t - \tau_m)$ and $p(t - \tau_l)$:

$$\rho(|\tau_m - \tau_l|) \triangleq N_f \int_0^{T_f} p(t - \tau_m) p(t - \tau_l) dt$$

In the case when distinct paths are orthogonal (such as $|\tau_m - \tau_l| > T_p, \forall m \neq l$), r_0 reduces to:

$$r_0 = (-1)^{b_0} E_s \sum_{l=0}^{L-1} h_l^2 \cos(2\pi f_0 \tau_l)$$

Hence, for a fixed multipath channel, the loss due to the shifting of the reference in frequency is given by:

$$\frac{\sum_{l=0}^{L-1} h_l^2 \cos(2\pi f_0 \tau_l)}{\sum_{l=0}^{L-1} h_l^2}$$

thus establishing a mathematical justification for using the smallest frequency shift possible between the reference and data pulses.

The probability of error for the proposed system operating over a multipath fading channel is then easily established:

$$\begin{aligned} P_{FSR-UWB,MP} &= E_h \left[Q \left(\frac{E_s \sum_{l=0}^{L-1} h_l^2 \cos(2\pi f_0 \tau_l)}{\sqrt{\frac{5}{2} E_s N_0 \sum_{l=0}^{L-1} h_l^2 + T_s N_0^2 W}} \right) \right] \quad (9) \end{aligned}$$

which will be compared to that of the standard TR-UWB system [10]:

$$\begin{aligned} P_{TR-UWB,MP} &= E_h \left[Q \left(\frac{E_s \sum_{l=0}^{L-1} h_l^2}{\sqrt{4E_s N_0 \sum_{l=0}^{L-1} h_l^2 + 2T_s N_0^2 W}} \right) \right] \quad (10) \end{aligned}$$

IV. NUMERICAL RESULTS

Throughout this section, perfect receiver synchronization is assumed. Due to space limitations, the consideration of timing synchronization is relegated to [10]. There, it is demonstrated that a simple and accurate low-complexity timing synchronization algorithm exists for the proffered system.

Figures 3 and 4 show the average bit error performance for the proposed FSR-UWB system and the standard TR-UWB system, respectively, on an AWGN channel. The simulation parameters are as follows. The pulse shape is the second derivative of Gaussian with a zero-to-zero pulse width of 1.2 ns. The noise bandwidth, corresponding to that of the front end filter, is 2.5 GHz (one-sided). Each symbol period consists of N_f frames, each of length 40 ns. For the simulation results, more than $\frac{100}{\hat{P}_b}$ data symbols have been run for each point, where \hat{P}_b is the displayed error probability estimate. These figures reveal that the analytical results of (6) and (7) match extremely well with simulation at the higher error rates where simulation can be efficiently performed.

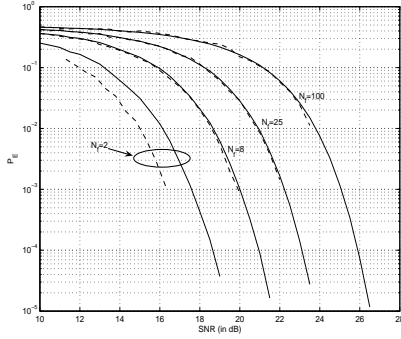

Fig. 3. (U) The bit error probability versus average signal-to-noise ratio for the proposed FSR-UWB system on an AWGN channel. Dashed lines correspond to simulation results, whereas solid lines correspond to the analytical results of (6).

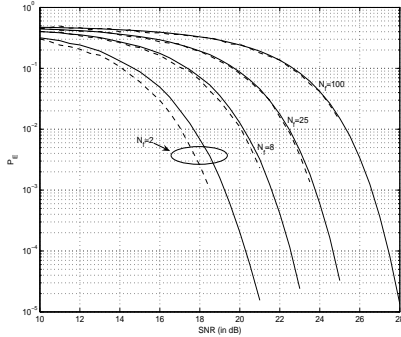

Fig. 4. (U) The bit error probability versus average signal-to-noise ratio for the standard TR-UWB system on an AWGN channel. Dashed lines correspond to simulation results, whereas solid lines correspond to the analytical results of (7).

The only exception to this rule is for the case of $N_f = 2$ frames per symbol, where the approximations made throughout this paper for performance characterization break down. Although the $N_f = 2$ case will not likely be of interest in the low data rate applications targeted, it is interesting to note that the proposed system still performs well despite the very coarse sampling of the desired transmitted waveform to which the receiver is matched.

As expected from previous performance analyses of TR-UWB, performance improves as N_f is decreased, which results in the allocated transmit power per symbol being concentrated in fewer pulses. In many applications, the pulse energy will be constrained, and, hence, the need to drive $\frac{E_s}{N_0}$ to the desired operating region will result in large values of N_f . Finally, and perhaps most importantly, the numerical results support the comparison of (6) and (7) in the “noise cross noise” regime, and the expected 1.5 dB gain of the FSR-UWB system over the TR-UWB system in this regime is apparent.

Next, the performance in a multipath fading environment is considered via (9) and (10). Recall that,

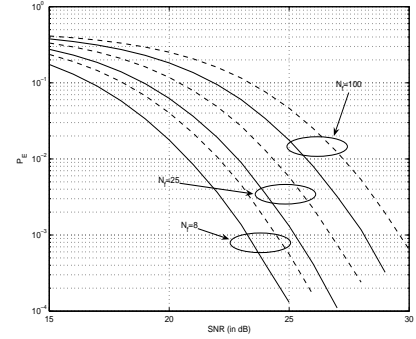

Fig. 5. (U) The bit error probability versus average signal-to-noise ratio for the TR-UWB system (dashed lines) and FSR-UWB system (solid lines) operating over a multipath fading channel. The system parameters are the same as those for Figure 3. Results are obtained by generating 10^5 random channels \underline{h} for each data point and using such to empirically estimate the expectations in (9) and (10).

in the multipath fading environment, a slightly higher performance degradation is expected of the FSR-UWB system versus the standard TR-UWB system, particularly for higher data rates and larger delay spreads, since the reference pulse goes through a channel that is frequency offset by f_0 from that of the data pulse. The multipath model considered here is a discrete-path model given by (8), where the path delays will be assumed to be at a fixed even spacing (i.e. $\tau_l = l\tau_1$) with $\tau_1 = 2$ ns. The path gains will be zero-mean Gaussian with variance given by an exponentially decaying multipath intensity profile:

$$E[h_l^2] = \frac{1}{\bar{\tau}} e^{-\frac{l\tau_1}{\bar{\tau}}},$$

where $\bar{\tau} = 15$ ms, and the average aggregate power in all of the paths is always kept fixed at unity. The performance of the FSR-UWB and TR-UWB systems under such a channel model is shown in Figures 5. In each case, the FSR-UWB system maintains nearly its full 1.5 dB advantage over the TR-UWB system - despite the fact that the FSR-UWB reference pulse goes through a slightly different channel than the FSR-UWB data pulse.

A. DISCUSSION

The comparison of the proposed system with standard TR-UWB changes slightly if the transmitter is peak power limited *at the frame level*. Note that spectra for FCC mask compliance are generally measured over a longer period of time, so this case applies more properly to a hardware constraint. In this case, the proposed FSR-UWB system exhibits a 4.6 dB peak-to-mean impulse power ratio, whereas the standard TR-UWB system has impulses all of identical power. Hence, making this adjustment to plot all results against the peak signal-to-noise ratio would yield a 3.1 dB gain for

the standard TR-UWB system. Even in this case, the FSR-UWB system would likely be preferable due to its simpler receiver implementation - recall that we only seek performance *comparable* to the standard TR-UWB system. In addition, since the FSR-UWB system only transmits a single impulse per frame per (2), under a peak power constraint the impulses can be sent more closely together over a fading channel while still guaranteeing no inter-frame interference and, hence, this loss is easily recouped.

Another method to get improved bit error performance versus average signal-to-noise ratio is with on-off keying and a receiver similar to that in Figure 2(b), but, of course, without the mixing with $\cos(2\pi f_0 t)$ [7]. However, on-off keying has its own implementation problems, particularly the need to set a decision threshold at the receiver, which can be problematic in fading channel scenarios. Both standard TR-UWB and the proposed FSR-UWB avoid such a requirement by using an antipodal data pulse so that the threshold is always 0, regardless of the channel gain.

If the system is implemented precisely as described in Section II, it may introduce spectral lines due to the periodicity of the pulses in $u(t)$. However, as pointed out underneath (1), the regular structure of $u(t)$, while convenient for the analysis, is not a requirement for operation of the system. In particular, any set of impulse locations that allow for a relatively uniform and dense sampling of the interval $[0, T_s]$ will lead to a system with virtually identical performance. Hence, in the most likely scenario, spectral lines would be mitigating by dithering the impulse locations across the first half of each frame.

Finally, we note that there are many methods through which the FSR-UWB system can be improved in the same manner as standard TR-UWB systems (see [8] for an example of improved receivers for the latter). In particular, if accurate frame timing is achievable, the integration interval $[0, T_s]$ can be reduced to only those times for which the noiseless received signal has support. In addition, data bits carried on separate carriers that use the same reference can further improve performance at low-to-moderate SNRs while still avoiding the need for a delay element, whereas the analogous improvement for standard TR-UWB exacerbates the delay element problem.

V. CONCLUSIONS

In this paper, it has been shown that the need for a delay element in the receiver of a transmitted reference UWB system can be obviated by employing a data pulse that is offset in frequency (rather than time) from the reference pulse. By observing that the data signal and

reference signal need only be orthogonal across the entire symbol period, the frequency offset can be chosen small enough to be well less than the coherence frequency of the channel, as required for the reference signal to be effective in sounding the proper channel for the data signal. Such an architecture not only greatly simplifies receiver design, but numerical results also indicate that the proposed scheme significantly outperforms the standard TR-UWB scheme in terms of bit error rate versus average signal-to-noise ratio. A simple synchronization scheme also exists for the proffered system.

ACKNOWLEDGMENTS

We are indebted to the participants in the UWB session at the 2004 Asilomar Conference on Signals, Systems, and Computers, whose active and frank discussion on the limitations of various forms of UWB receivers led to the motivation for this work that is described in the Introduction. Special thanks goes to Wesley Gifford of the Massachusetts Institute of Technology (MIT) for fruitful discussions regarding his Asilomar 2004 paper and for providing an advance version of [9].

REFERENCES

- [1] M. Win and R. Scholtz, "Ultra-wide Bandwidth Time-Hopping Spread-Spectrum Impulse Radio for Wireless Multiple Access Communications," *IEEE Transactions on Communications*, Vol. 48: pp. 679-691, April 2000.
- [2] R. Wilson and R. Scholtz, "Comparison of CDMA and Modulation Schemes for UWB Radio in a Multipath Environment," *Proceedings of the Global Telecommunications Conference*, December 2003.
- [3] H. Sheng, R. You, and A. Haimovich, "Performance Analysis of Ultra-Wideband Rake Receivers with Channel Delay Estimation Errors," *Proceedings of the Conference on Information Sciences and Systems*, 2004.
- [4] R. Hocht and H. Tomlinson, *An Overview of Delay-Hopped, Transmitted-Reference RF Communications*, General Electric Technical Report 2001CRD198, January 2002.
- [5] L. Yang and G. Giannakis, "Timing Ultra-Wideband Signals with Dirty Templates," submitted to the *IEEE Transactions on Communications*, 2004.
- [6] J. Choi and W. Stark, "Performance of Ultra-Wideband Communication with Suboptimal Receivers in Multipath Channels," *IEEE Journal on Selected Areas in Communications*, Vol. 20: pp. 1754-1766, December 2002.
- [7] H. Zhang and D. Goeckel, "Generalized Transmitted-Reference UWB Systems," *Proceedings of the Conference on Ultra-Wideband Systems and Technologies (UWBST)*, November 2003.
- [8] Y. Chao and R. Scholtz, "Optimal and Suboptimal Receivers for Ultra-Wideband Transmitted Reference Systems," *Proceedings of the Global Telecommunications Conference*, December 2003.
- [9] W. Gifford and M. Win, "On Transmitted-Reference UWB Communications," *Proceedings of the Asilomar Conference on Signals, Systems, and Computers*, 2004.
- [10] D. Goeckel and Q. Zhang, "Slightly Frequency-Shifted Reference Ultra-Wideband (UWB) Radio", submitted to the *IEEE Transactions on Communications*, June 2005.